



## Ford Focus QuickLIFT Installation Guide

### Step 1 - Unpack QuickLIFT package and verify the contents.

Remove all items from the packing tube. You should have the following before beginning:

- \* (2) Gas Charged Springs - *Be sure to cycle each spring a few times before installing*
- \* (8) 3/16" Multi-grip rivets - Version 2.00+ of this QuickLIFT kit now supports aftermarket hoods.
- \* (4) Steel ball-stud brackets
- \* Printed Instructions
- \* Gas Spring locking clips - these come pre-installed in the gas springs. **REMOVE** them and put them in a safe location until they are needed at the end of the installation process. They are easily lost if dropped and are expensive to replace - **BE CAREFUL NOT TO LOSE THEM!**



### Step 2 - Gather required tools.

Please gather the following tools before you begin the installation:

- \* Power Drill
- \* 3/16", indexed #11 & 1/4" drill bits
- \* Masking Tape
- \* Tape Measure or ruler
- \* Fine permanent marker or felt tip pen
- \* Hammer & center punch
- \* Rivet gun, capable of 3/16" steel rivets

*Note: Only use the rivets supplied in the QuickLIFT kit.*



*Recommended: Craftsman standard or Swivel Riveter (shown - 974749) - \$9.99 to \$17.99*

### Step 3 - Align bracket & mark left hole for drilling.

A. Line up the bracket as shown in Figure 3a.

The top edge of the bracket should be in line with the fender mounting flange, which is also **1-3/4 inches (44 mm)** from the fender mounting bolt's centerline.

B. Mark the center of the left hole in the bracket with a permanent marker as shown in Figure 3b.

C. Using center punch and hammer, tap center of spot you marked.

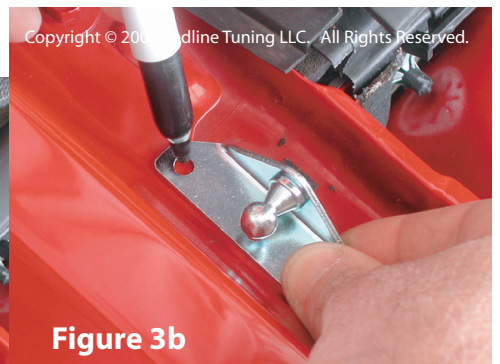

## Step 4 - Drill #11 indexed bit hole, or 3/16" hole.

A. Carefully drill the hole as shown to the right using a (#11 indexed bit) or (use 3/16" bit if #11 bit is not available).

If you do not have a #11 indexed bit, you can use the 3/16" bit, however you may have to test fit the rivet and slightly ream hole until rivet fits tightly through bracket and hole - 3/16" is slightly smaller than the #11 bit.

**Wrap a piece of electrical tape around the drill bit about 1/4" from the tip to prevent the bit from denting the hood skin. Use new and sharp bits!**



Optional: Use touch up paint to protect hole.



Test fit rivet in hole.

## Step 5 - Rivet left side of bracket to vehicle.

A. With the bracket lined up again, place a rivet through the bracket and fender hole with the long stem sticking upright - shown in Figure 5a.

B. Check to be sure your rivet gun has the 3/16" rivet head installed, then slide rivet gun onto rivet. While applying downward force on rivet and bracket, firmly squeeze riveter handle multiple times until rivet gun pops and snaps off the rivet - shown in 5b. **Carefully remove tool and allow rivet stem to fall from riveter.**



Figure 5a

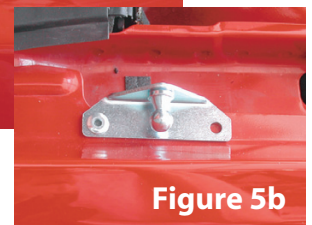

Figure 5b

## Step 6 - Align bracket and drill right hole.

A. Align the bracket parallel to the fender.

B. Use a center punch and hammer to indent the center of the hole in the bracket - this will help guide the drill bit and keep it from wandering.

C. Carefully drill the second hole using the bracket as a guide. Be careful not to let the bracket wander while drilling.

Test fit rivet in right hole. Remember that you might have to twist or wiggle the rivet end into the hole. The rivet should stand upright once securely pushed into hole as shown to the right.



Copyright © 2003 Redline Tuning LLC. All Rights Reserved.

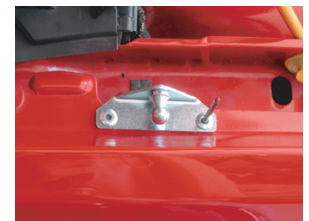

## Step 7 - Rivet the other side of bracket to vehicle.

Install second rivet following the same directions described in Step 5. Bracket should be secure once riveting is completed.

Again, be careful when rivet gun releases after the head snaps off - you don't want to scratch your paint. Remove the rivet stem from riveter.



Copyright © 2003 Redline Tuning LLC. All Rights Reserved.



## Step 8 - Repeat steps 3-7 to install the driver's side fender bracket.

Since the vehicle has symmetrical fenders, repeat steps 3 thru 7 to install the bracket onto the driver's side fender. Figure 8a shows the correct placement, and Figure 8b shows the bracket after both rivets have been installed. Both fender brackets should be completed before proceeding to step 9.

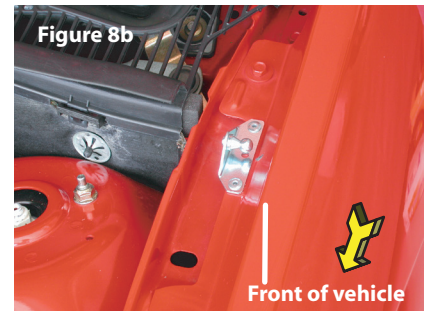
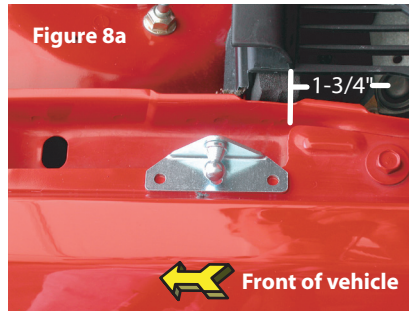

## Step 9 - Measure and mark centerline of hood bracket - Driver's side.

A. Place a piece of masking tape along the driver's side edge of the hood as shown in Figure 9a.

B. Draw a line perpendicular to the edge of the hood at **4 - 5/16" (108 mm)** from the front corner. Measurement can be within 1/4" of 4-5/16".



Figure 9b

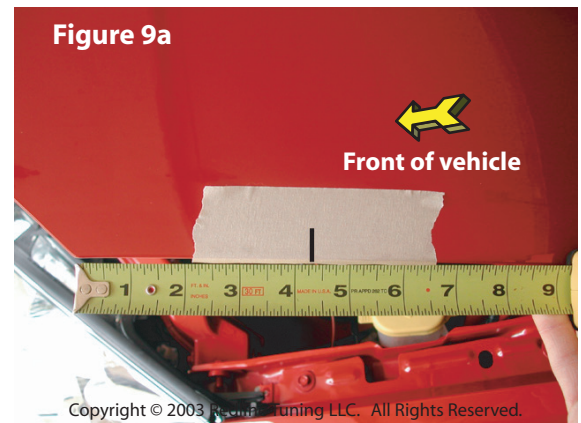

## Step 10 - Mark the first hole to drill.

A. Using the centerline as a guide for the center of the bracket, place bracket in corner just under the hood with the ball end facing down and away from hood. Refer to Figures 10b and Figure 10a.

B. Using your felt tip marker, mark the center of one of the holes in the bracket. You may want to put a piece of tape down in the area prior to marking, but it is not required.

C. Carefully drill the hole as shown to the right using a **(#11 indexed bit)** or **(use 3/16" bit if #11 bit is not available)**.



Figure 10a



Figure 10b



Figure 10c

## Step 11 - Install rivet to attach bracket.

A. Remove tape under hood after hole is drilled.

B. Place rivet thru both bracket hole and through hole in hood. Be sure that the end of the rivet is fully inserted before riveting begins...

C. While applying force to rivet and bracket with the riveter, firmly press handle multiple times until rivet fully compresses and breaks free.



## Step 12 - Mark center of 2nd hole in bracket and drill hole.

- A. Verify bracket is still pressed into corner under hood edge as shown in Figure 12a.
- B. Using your felt-tip marker, mark the center of the remaining hole in bracket.
- C. Use a center punch to indent the center of the hole before drilling.
- D. Drill hole as described earlier.



Figure 12a



Figure 12b

## Step 13 - Install second rivet in driver's side hood bracket.

- A. Place rivet thru both bracket hole and hole in hood. While applying force to rivet and bracket with the riveter, firmly squeeze handle multiple times until rivet fully compresses and breaks free.

Bracket should be secure.

## Step 14 - Repeat steps 9 thru 13 for the passenger side hood bracket.

- A. Carefully repeat steps 9 thru 13 to install the hood bracket on the passenger side of the vehicle. Follow steps carefully, remembering to correctly measure and mark the centerline of the bracket before positioning bracket and drilling holes.

## Step 15 - Cycle both gas springs 3 times

- A. **CYCLE EACH GAS SPRING BEFORE INSTALLING** - firmly hold a gas spring with both hands by the thick cylindrical end - firmly press down on the floor or carpet and compress the spring. Do this to both gas springs a few times to lubricate the shaft before installing them.

## Step 16 - Install driver's side QuickLIFT shock.

- A. Snap QuickLIFT gas spring onto each ball stud. The larger diameter black housing attaches to the hood bracket and the shaft extension attaches to the fender bracket. **NOTE - be sure to remove the safety clips prior to installing the shocks. They are installed on the shocks during shipping and need to be removed before snapping the shocks on.**

## Step 17 - Install passenger side QuickLIFT gas spring.

- A. Install QuickLIFT gas spring on passenger side of vehicle following the same instructions as the driver's side. Have a friend continue to hold hood until Step 18 is complete.

## Step 18 - Install locking clips into each gas spring.

- A. Install the locking clips into each shock end (area surrounding ball on bracket). These locking clips keep the shock ends from coming off when bumped from the side. Follow the images below if you are unsure how they are inserted. The clips will lock the struts to the ball-studs.



Line up pin with hole.



Slide pin thru hole.



Rotate curved section around ball end until it snaps firmly.